

01 WALL CROSS SECTION
SCALE 1:25

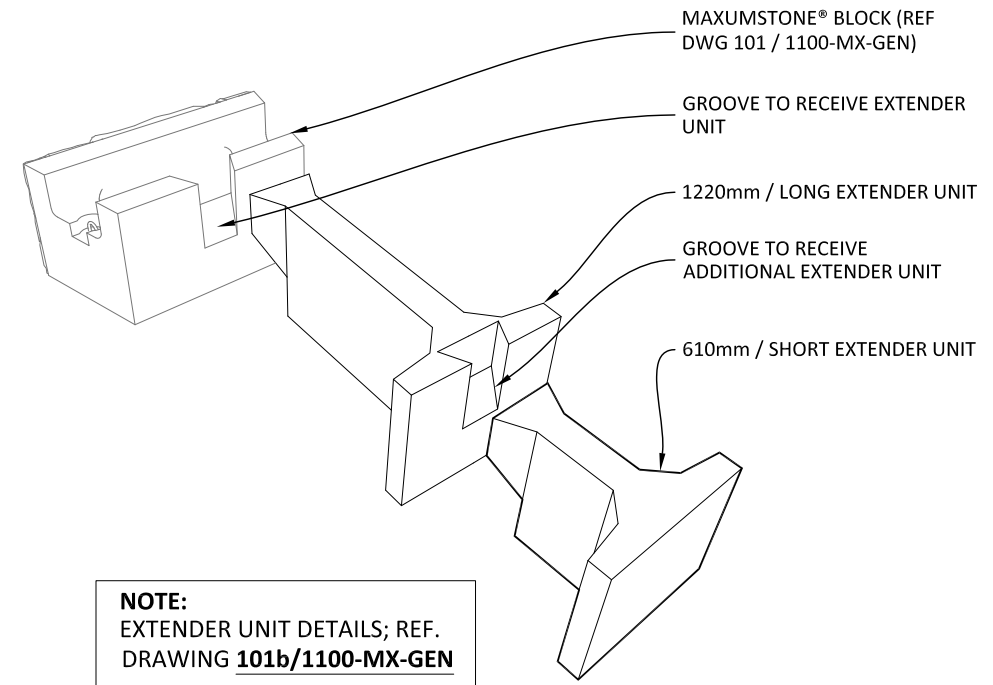

02 ISOMETRIC VIEW

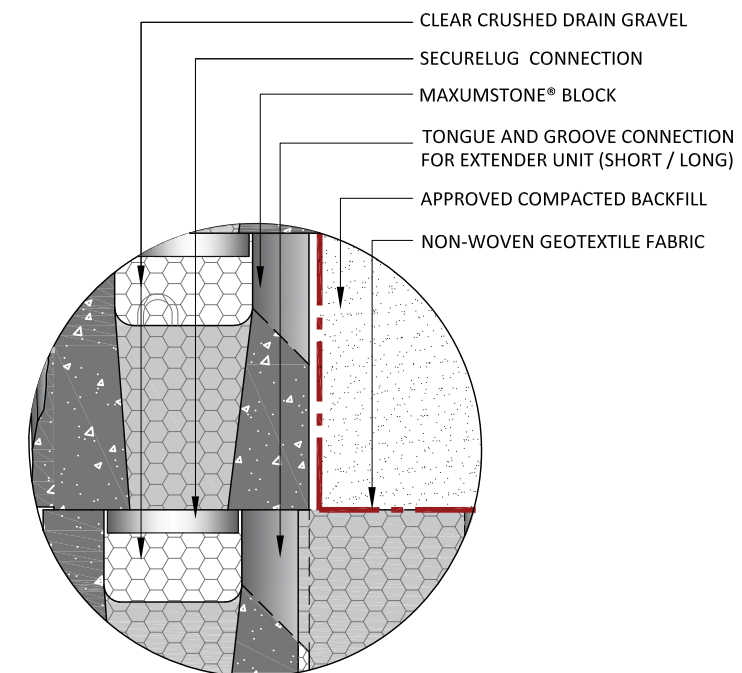

03 DETAIL
N.T.S.

GENERAL NOTES:

These drawings are intended solely to act as an aid when designing a wall. This drawing should not be used for final design or construction.

Each site-specific wall should be certified and signed by a registered geotechnical engineer in the State or Province that it is being built.

The accuracy and use of the details in this document are the sole responsibility of the user.

Rev	DESCRIPTION	DATE
01	ADDENDUM INFORMATION	08-10-2023
00	INTERNAL APPROVAL	07-01-2023

REMARKS:

- PURPOSE OF ISSUE:**
- INFORMATION
 - REVIEW / APPROVAL
 - PRODUCTION

SHEET CONTENT

MAXUMSTONE® GRAVITY WALL CROSS SECTION DETAILS

SHEET REFERENCE

101

1102-MX-GVT

DRAWING INFORMATION

SCALE : AS INDICATED
PAPER SIZE : 431.8mm X 279.5mm
PREPARED BY : RM



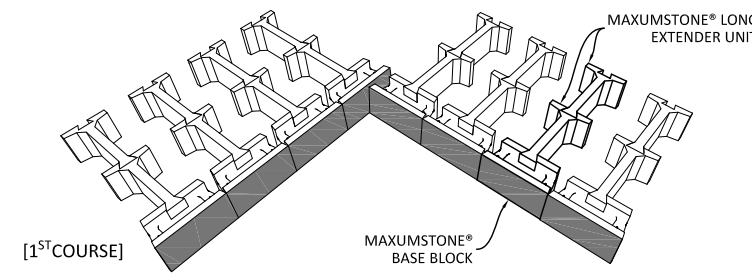
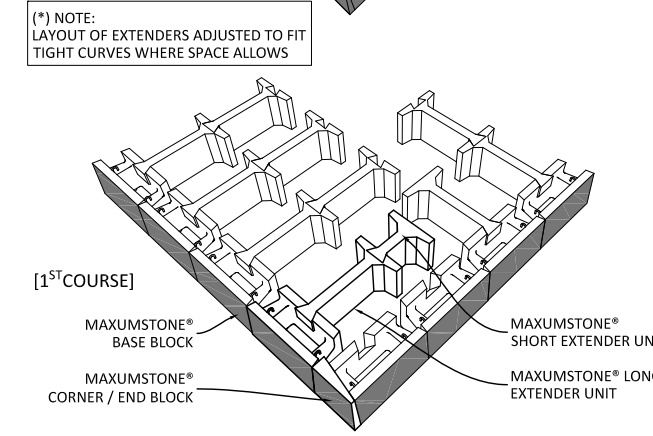
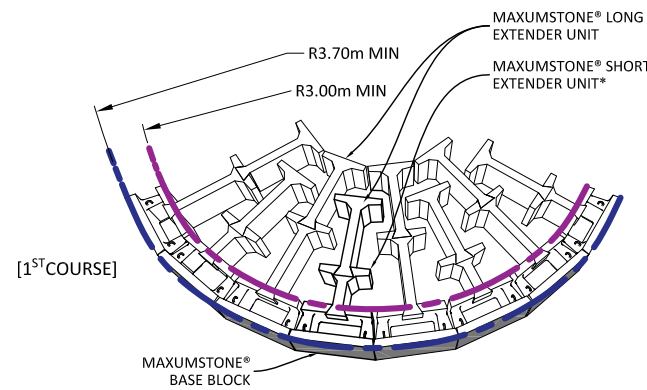
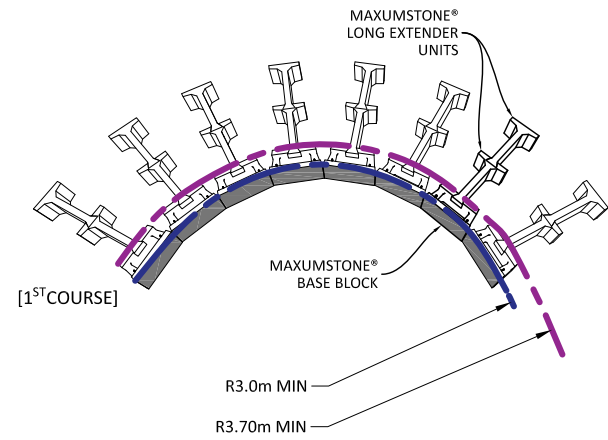
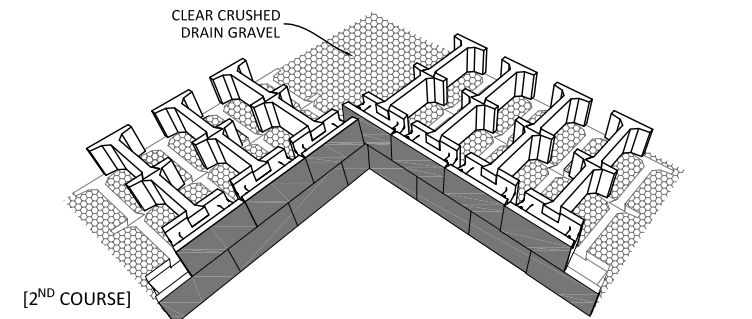
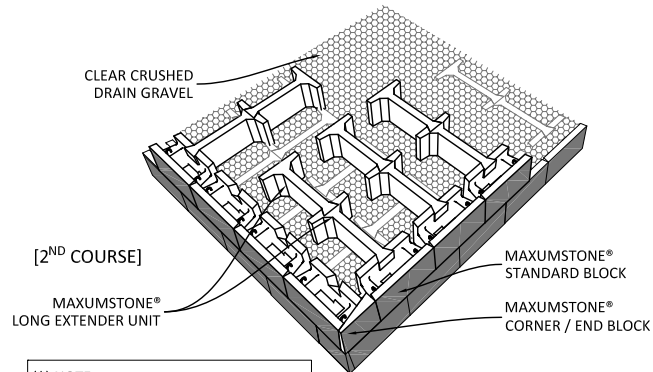
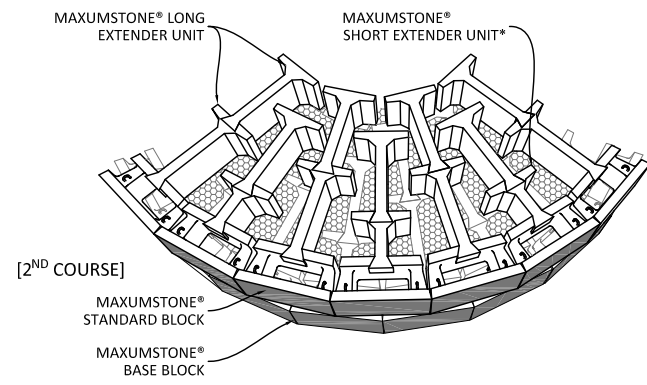
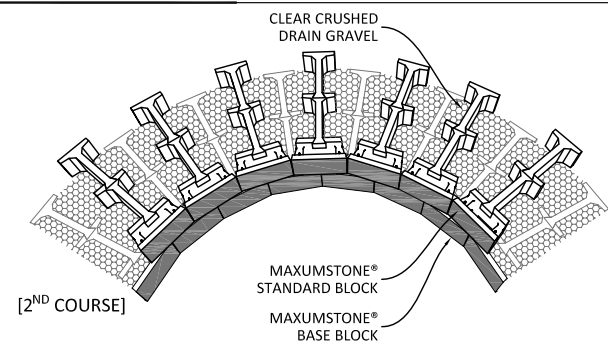

(* NOTE: LAYOUT OF EXTENDERS ADJUSTED TO FIT TIGHT CURVES WHERE SPACE ALLOWS)

INSIDE CURVE

01 CURVES AND CORNERS

N.T.S.

OUTSIDE CURVE

OUTSIDE CORNER

INSIDE CORNER

GENERAL NOTES:

These drawings are intended solely to act as an aid when designing a wall. This drawing should not be used for final design or construction.

Each site-specific wall should be certified and signed by a registered geotechnical engineer in the State or Province that it is being built.

The accuracy and use of the details in this document are the sole responsibility of the user.

Rev	DESCRIPTION	DATE
01	ADDENDUM INFORMATION	08-10-2023
00	INTERNAL APPROVAL	07-01-2023

REMARKS:

PURPOSE OF ISSUE:

- INFORMATION
- REVIEW / APPROVAL
- PRODUCTION

SHEET CONTENT

MAXUMSTONE® GRAVITY WALL COMMON APPLICATION

SHEET REFERENCE

102

1102-MX-GVT

DRAWING INFORMATION

SCALE : AS INDICATED
 PAPER SIZE : 431.8mm X 279.5mm
 PREPARED BY : RM

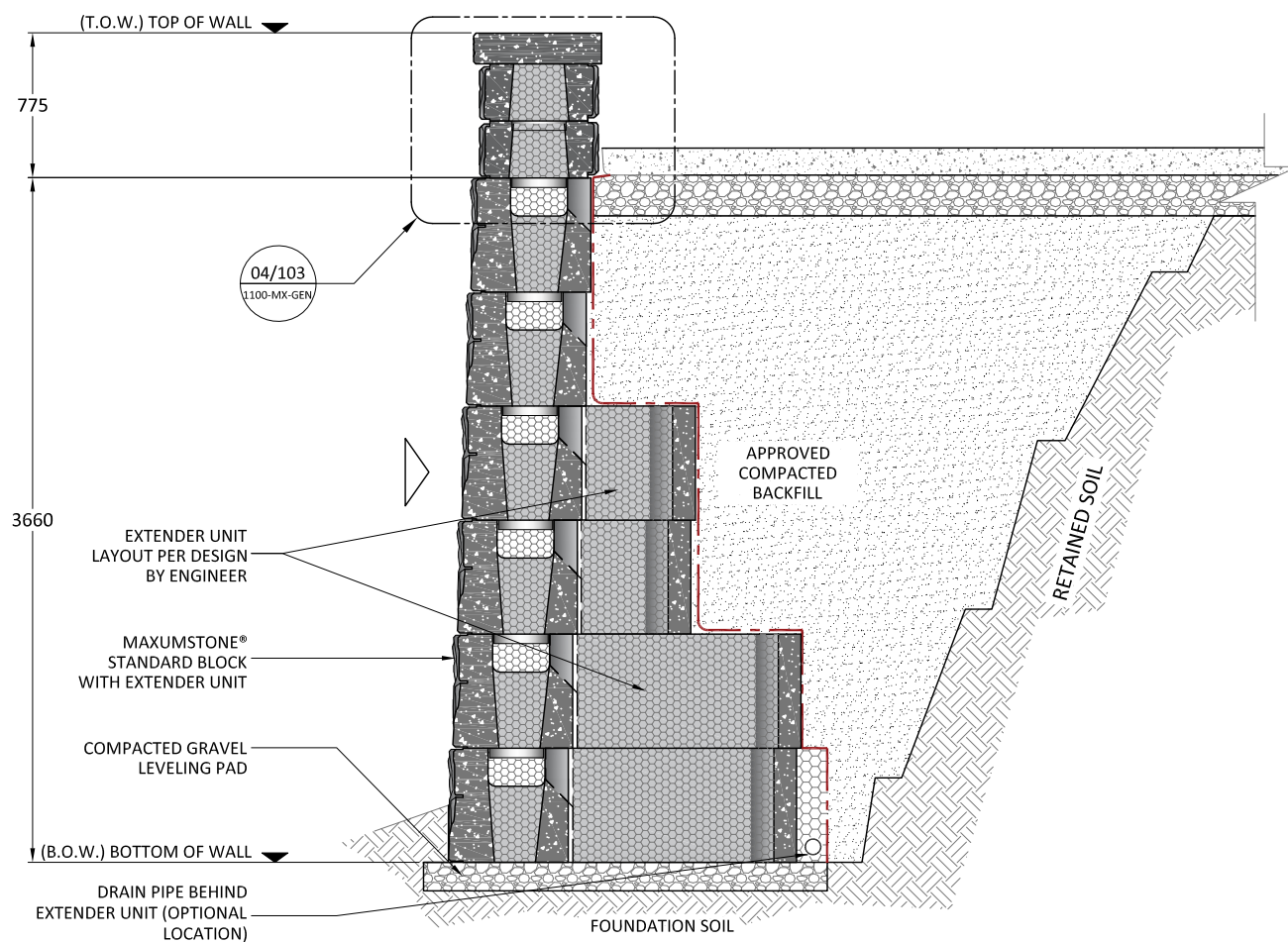

02 FREESTANDING SEATING WALL ON GRAVITY WALL

SCALE 1:40

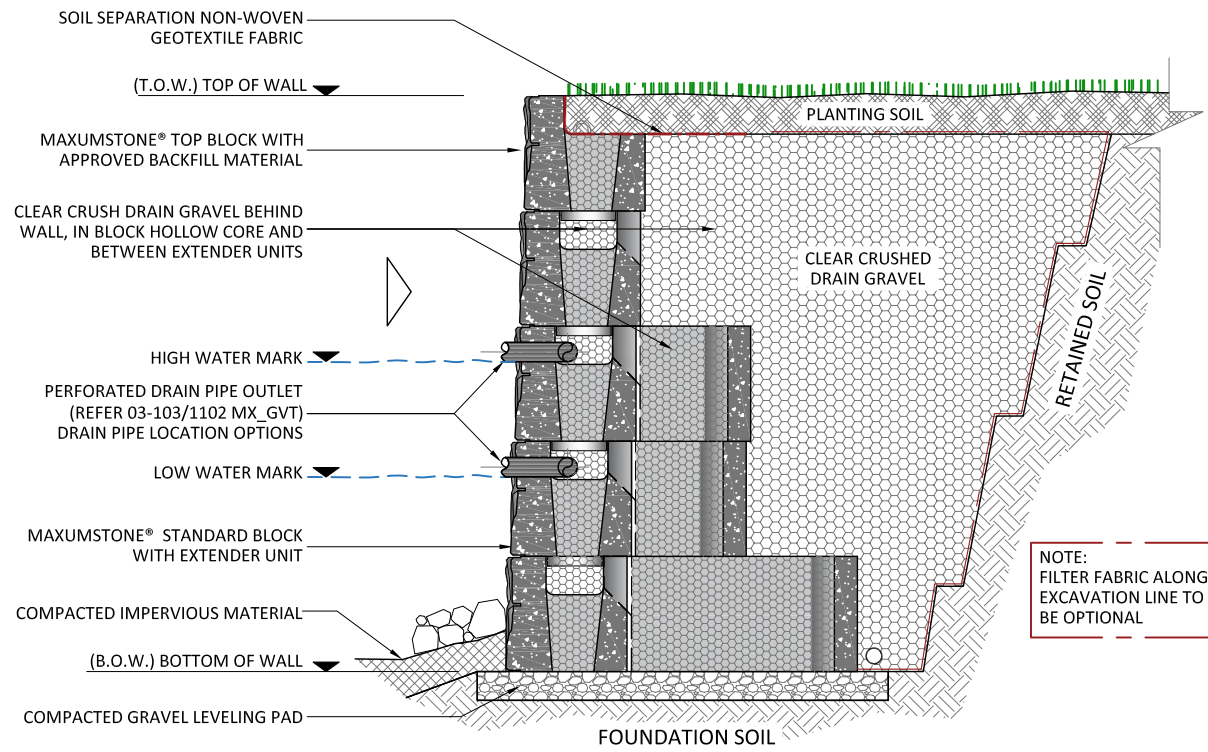

03 WATER APPLICATION OF GRAVITY WALL

SCALE 1:40

EXTENDER UNIT - GENERAL NOTE:

- EXTENDER UNITS TO BE ATTACHED ONTO MAXUMSTONE® STANDARD, BASE BLOCK OR ANOTHER EXTENDER UNIT TO CREATE DEEPER BLOCKS AND ADD MASS FROM THE STANDARD MAXUMSTONE® BLOCK
- EXTENDER UNITS USE A TONGUE-AND-GROOVE CONNECTION TO LOCK INTO THE BACK OF A PROVIDED GROOVE OF THE STANDARD MAXUMSTONE® BLOCK OR LONG EXTENDER UNIT
- EXTENDER UNITS ARE CHAINED TOGETHER IN 2' [610 mm] INCREMENTS. THE NUMBER OF EXTENDERS MAY BE DETERMINED BY THE ENGINEER ON RECORD THROUGH THE DESIGN ANALYSIS SOFTWARE.

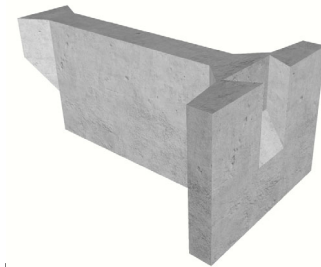

LONG EXTENDER



SHORT EXTENDER

NOTE:
EXTENDER UNIT DETAILS; REFER DRAWING 101b/1100-MX-GEN

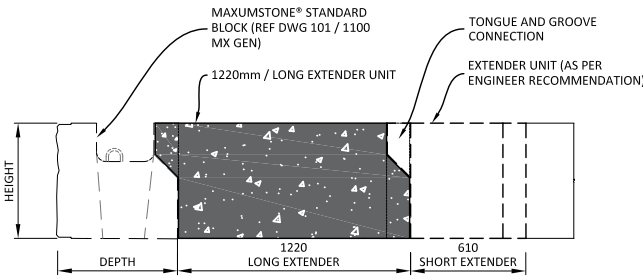

TYPICAL CROSS SECTION

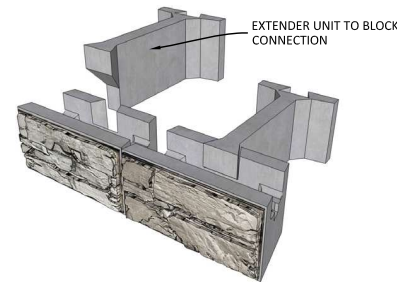

**ISOMETRIC VIEW
BLOCK-TO-EXTENDER UNIT**

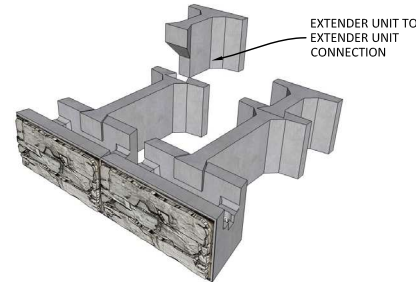

**ISOMETRIC VIEW
EXTENDER-TO-EXTENDER UNIT**

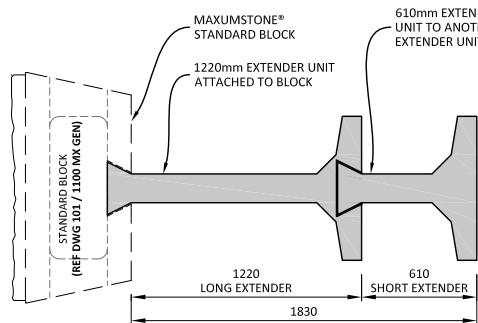

EXTENDER OPTION 01

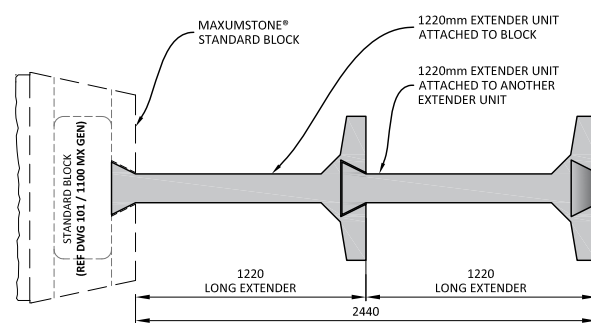

EXTENDER OPTION 02

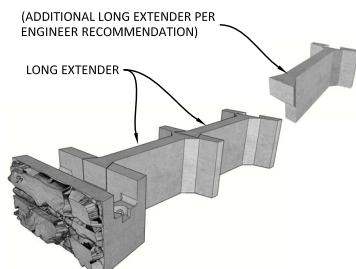

EXTENDER OPTION 03

01 EXTENDER UNIT CONFIGURATION

N.T.S.

02a FENCE OPTIONS
SCALE 1:50

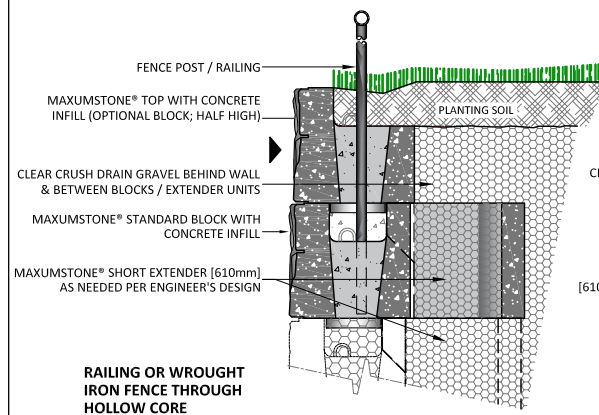

RAILING OR WROUGHT IRON FENCE THROUGH HOLLOW CORE

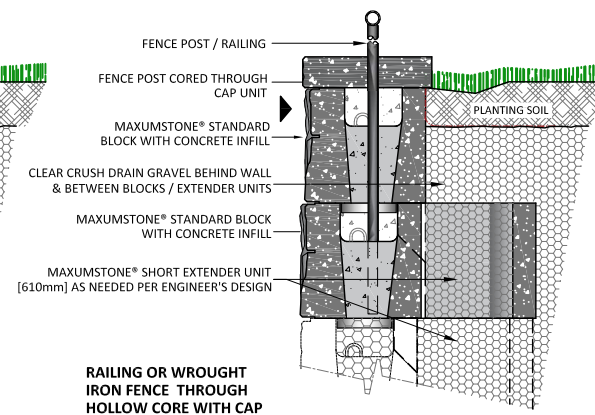

RAILING OR WROUGHT IRON FENCE THROUGH HOLLOW CORE WITH CAP

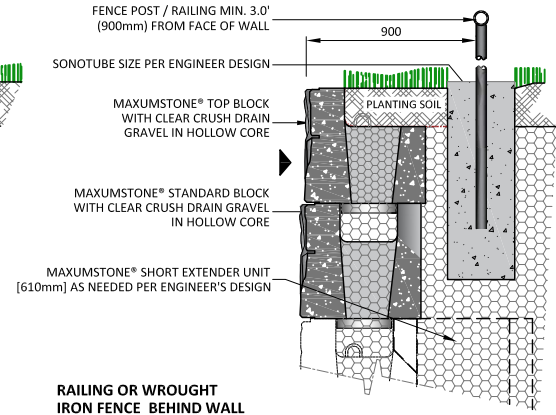

RAILING OR WROUGHT IRON FENCE BEHIND WALL

FENCE GENERAL NOTE:

- FENCE POST / RAILING DESIGN BY OTHERS
- DESIGN TO BE PERFORMED BY ENGINEER

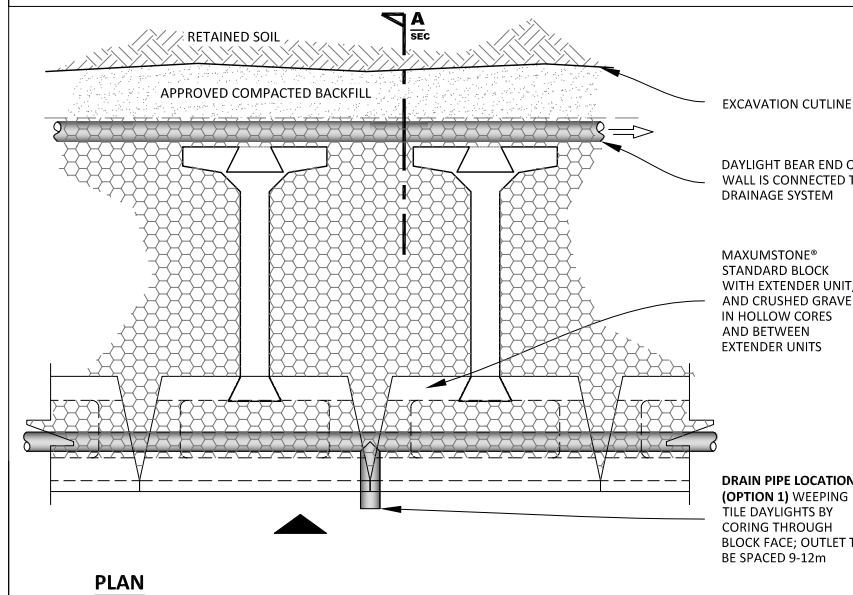

PLAN

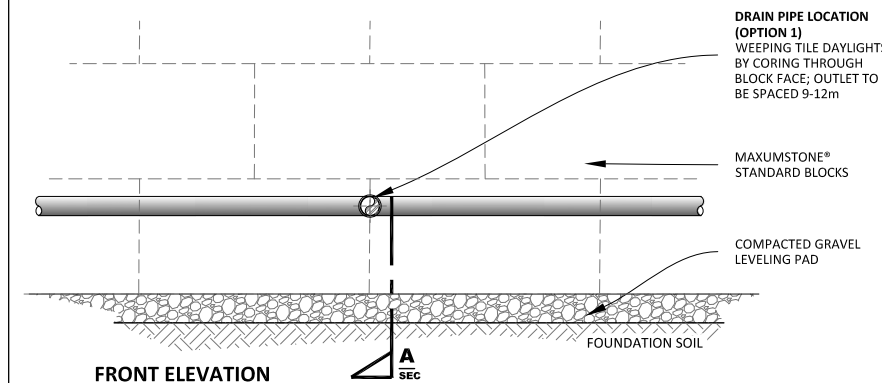

FRONT ELEVATION

03 DRAIN PIPE OPTIONAL LOCATION
GRAVITY RETAINING WALL 1:50

DRAIN PIPE - GENERAL NOTE:

- DRAIN PIPE LOCATIONS MENTIONED ABOVE ARE POTENTIAL DESIGN OPTIONS. OTHER OPTIONS ARE AVAILABLE AS PER ENGINEER'S DISCRETION
- WEEPING TILE DAYLIGHTS BY CORING THROUGH BLOCK FACE; OUTLET TO BE SPACED 30'-40' [9-12 m]

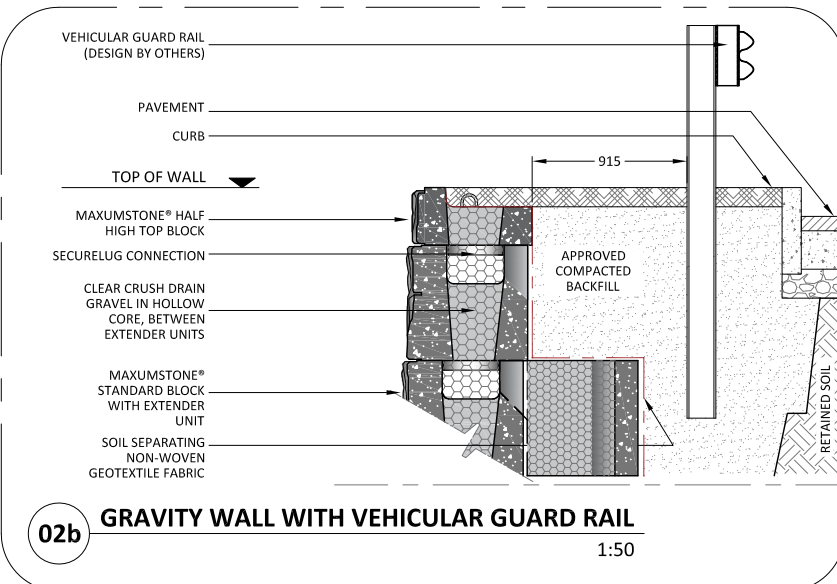

02b GRAVITY WALL WITH VEHICULAR GUARD RAIL
1:50

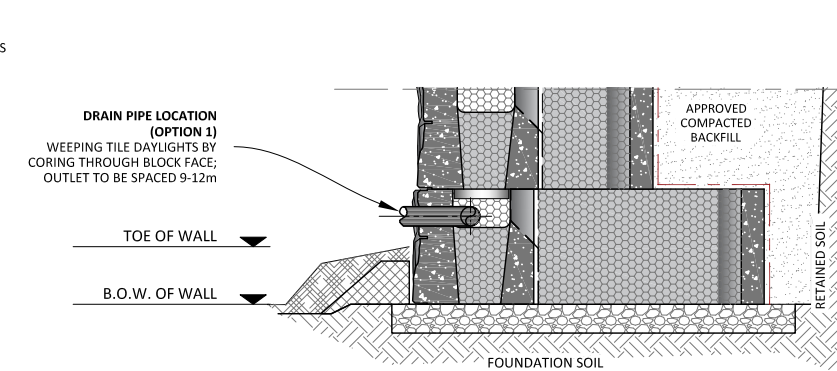

OPTION 01

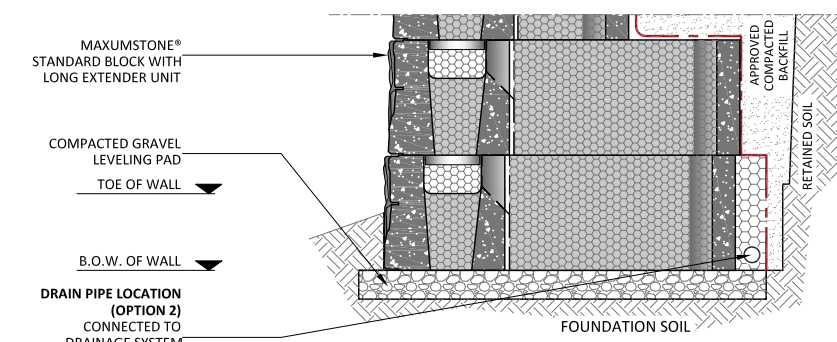

OPTION 02

GENERAL NOTES:

These drawings are intended solely to act as an aid when designing a wall. This drawing should not be used for final design or construction.

Each site-specific wall should be certified and signed by a registered geotechnical engineer in the State or Province that it is being built.

The accuracy and use of the details in this document are the sole responsibility of the user.

Rev	DESCRIPTION	DATE
01	ADDENDUM INFORMATION	08-10-2023
00	INTERNAL APPROVAL	07-01-2023

REMARKS:

PURPOSE OF ISSUE:

- INFORMATION
- REVIEW / APPROVAL
- PRODUCTION

SHEET CONTENT

**MAXUMSTONE®
GRAVITY WALL
ADDENDUM DETAILS**

SHEET REFERENCE

103

1102-MX-GVT

DRAWING INFORMATION

SCALE : AS INDICATED
PAPER SIZE : 431.8mm X 279.5mm
PREPARED BY : RM



MaxumStone®
RETAINING WALLS

www.maxumstone.co.uk | 1 (800) 939-9193

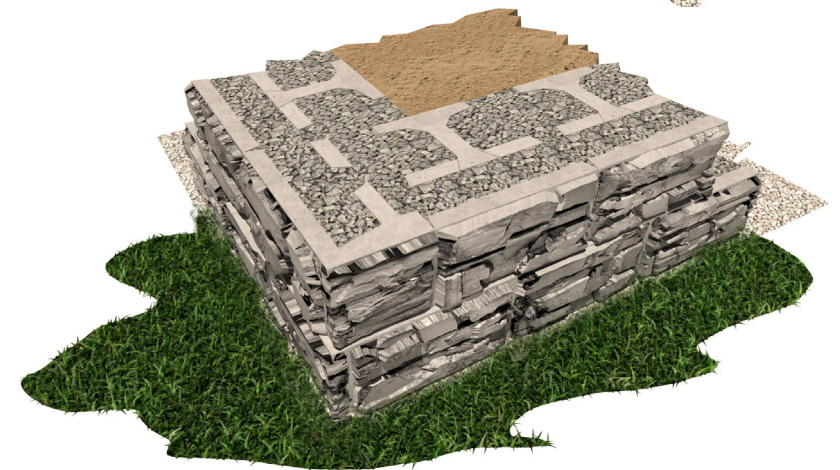
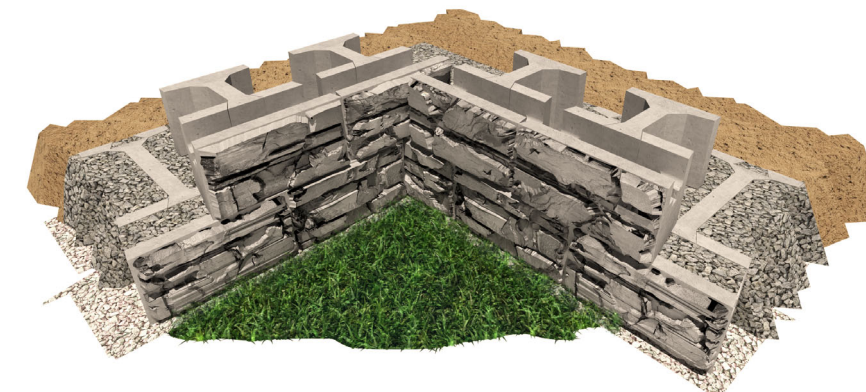
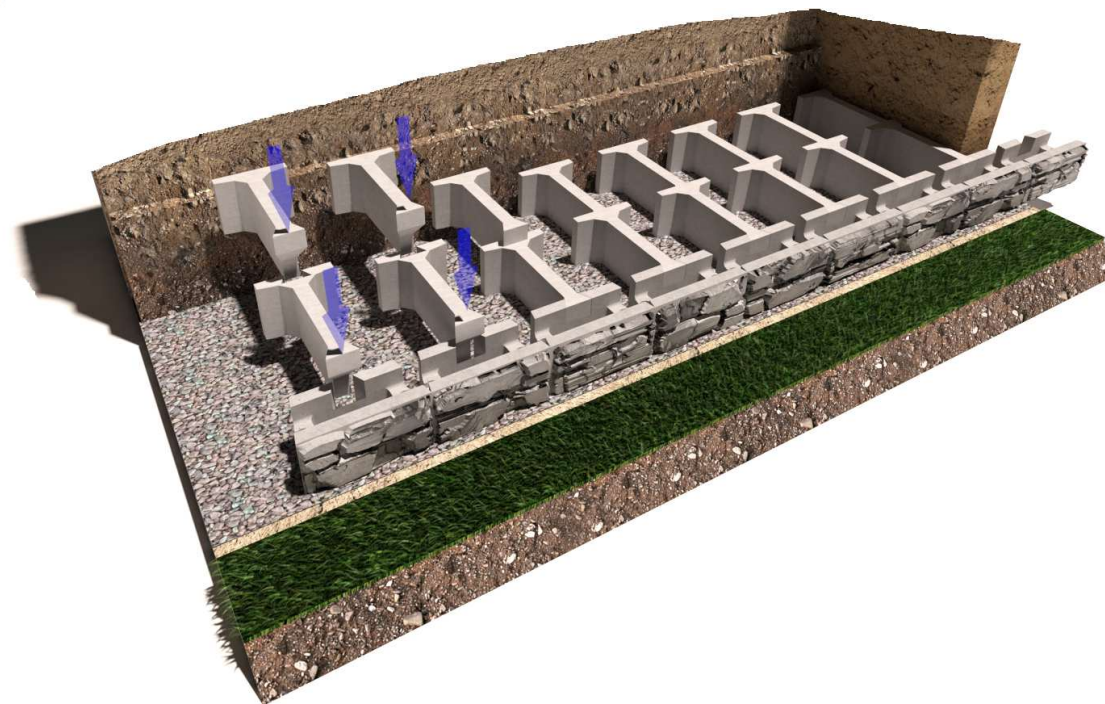
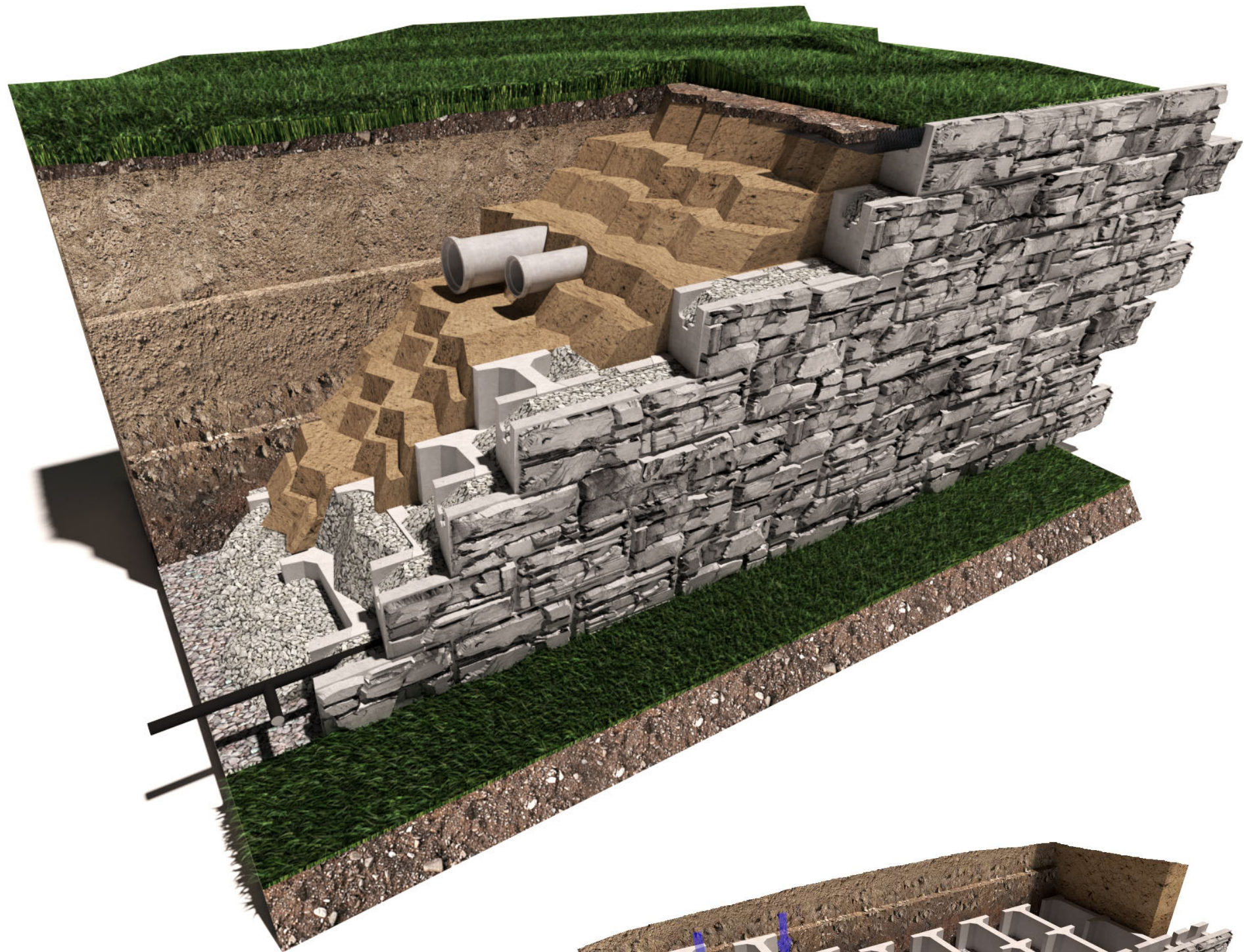

GENERAL NOTES:

These drawings are intended solely to act as an aid when designing a wall. This drawing should not be used for final design or construction.

Each site-specific wall should be certified and signed by a registered geotechnical engineer in the State or Province that it is being built.

The accuracy and use of the details in this document are the sole responsibility of the user.

Rev	DESCRIPTION	DATE
01	ADDENDUM INFORMATION	08-10-2023
00	INTERNAL APPROVAL	07-01-2023

REMARKS:

- PURPOSE OF ISSUE:**
- INFORMATION
 - REVIEW / APPROVAL
 - PRODUCTION

SHEET CONTENT
MAXUMSTONE®
GRAVITY WALL
PERSPECTIVE

SHEET REFERENCE

201

1102-MX-GVT

DRAWING INFORMATION

SCALE : AS INDICATED
 PAPER SIZE : 431.8mm X 279.5mm
 PREPARED BY : RM

